

5/16"-24 thread, should go as close to the shoulder as possible.

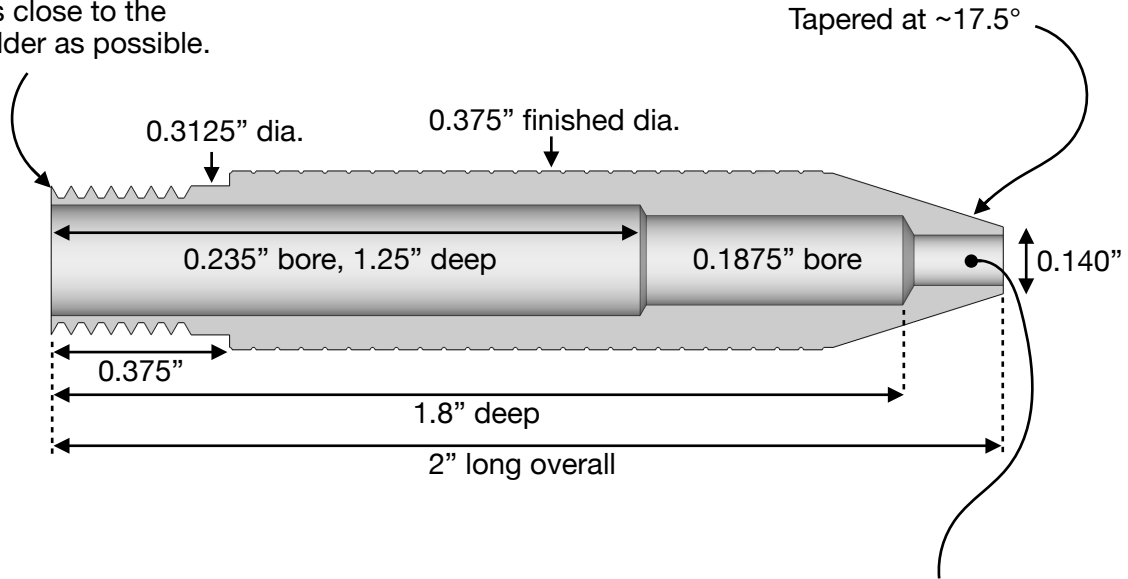

Diameter should fit the refill closely. I think the refill I used was exactly 0.100" diameter at the end, so I drilled 0.104"... or something like that. Might need to experiment if you want a perfect fit.

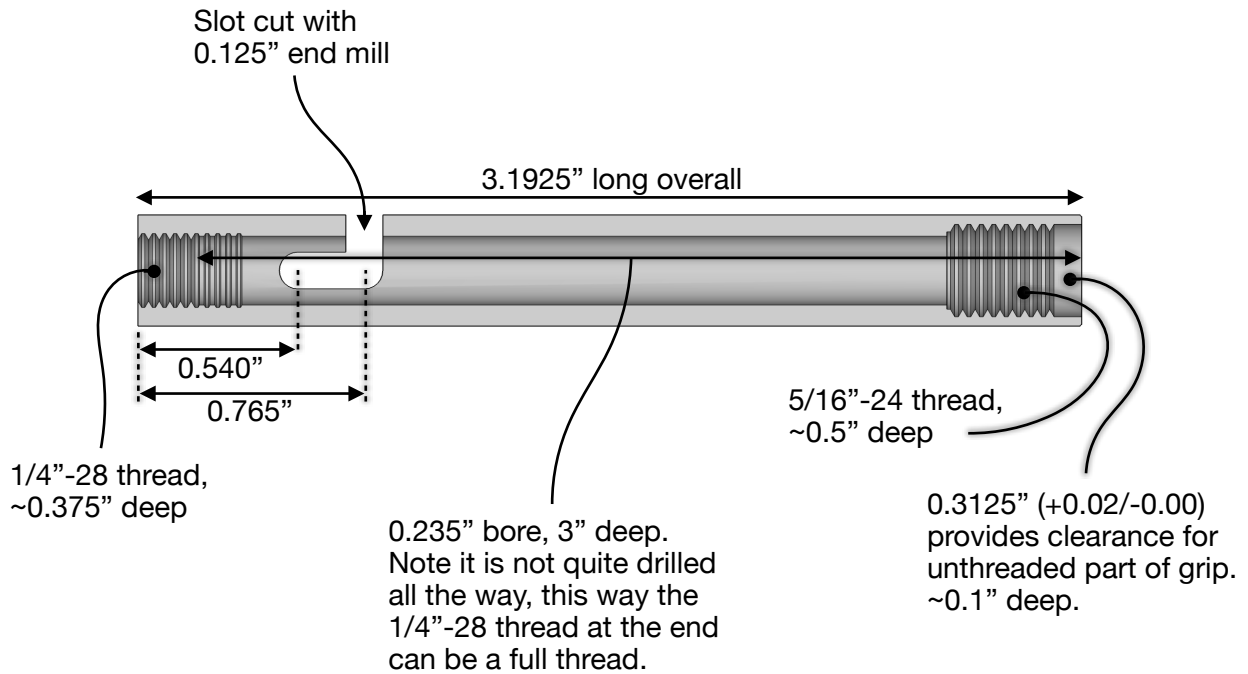

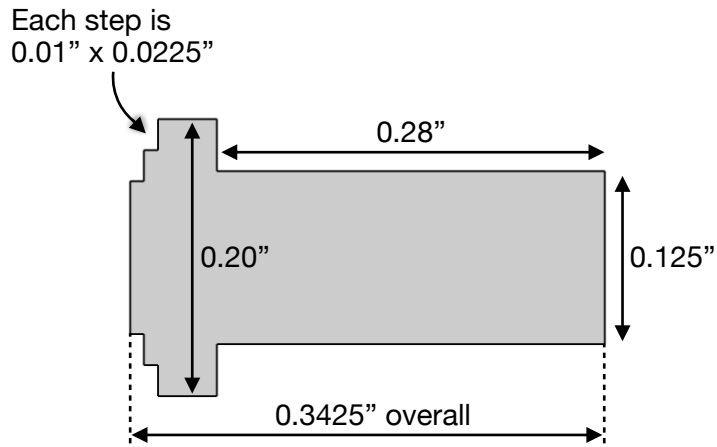
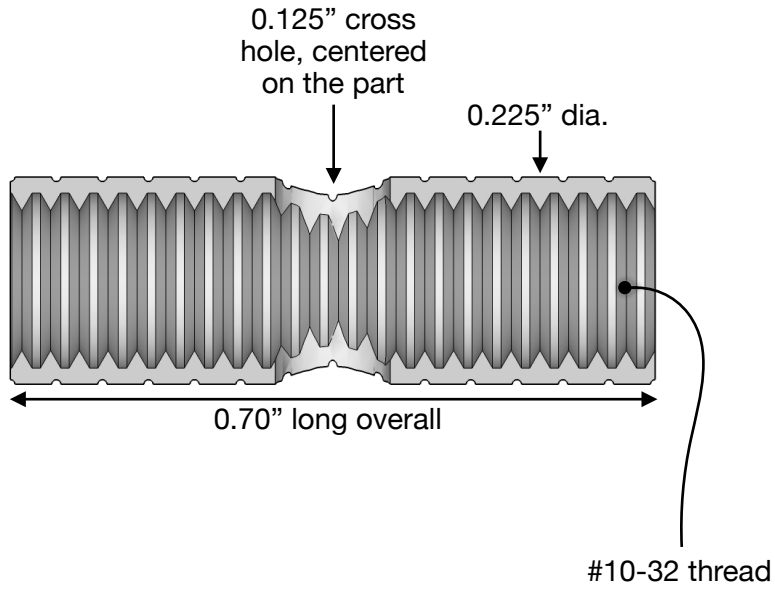

I made this part by modifying a button head screw, but figured I'd include it anyway. The shape of the head was just eyeballed to look nice.

